

Belt Drive Components

# Section 3 – Belt Drive Components

The TSplus belt drive powers the transport belt along the conveyor sections while the return units route the belt back through the return channel of the belt profile. Drives and returns can also be linked together end-to-end to create

extended conveyor lines of almost any length. Drive units are available in both standard and heavy duty models and have various electrical options and motor mounting positions.

**原装进口力士乐皮带  
代理商电话 18823303057**

**Belt Drive components in this section can be configured into any of the basic line layouts below.**

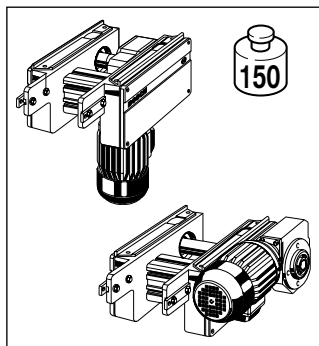
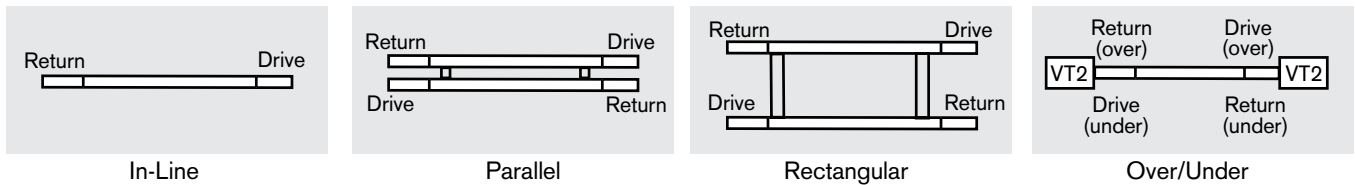

**AS2B/M, AS2B/S**  
Standard Belt Drives  
3-2 to 3-3

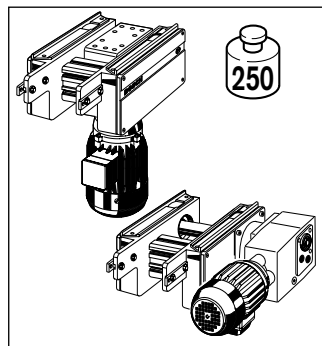

**AS2B/M-H, AS2B/S-H**  
Heavy Duty Belt Drives  
3-4 to 3-5

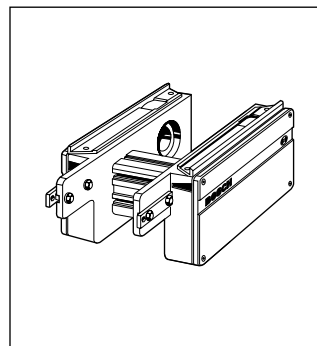

**UM2/B**  
Return Units  
3-6

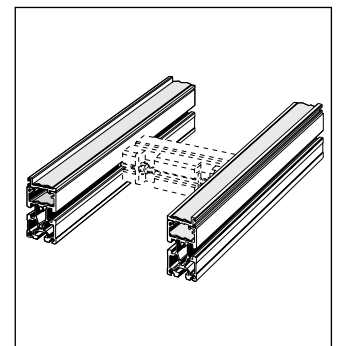

**ST2/B, ST2/B100**  
Belt Conveyor Sections  
3-7

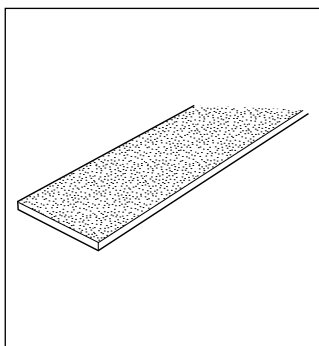

**GT2/B**  
Transport Belt  
3-8

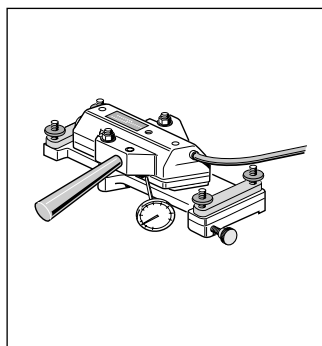

**Belt Welding Equipment**  
3-9

Belt Drive Components

# Belt Drive Module

Model AS2B/M, AS2B/S

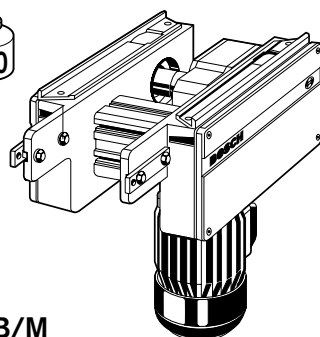

AS2B/M

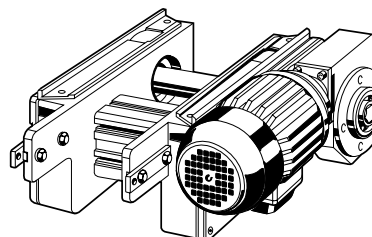

AS2B/S

The AS2B/M and AS2B/S drive modules power the conveyor belts. The AS2B/S has an outboard mounted gearbox, while the AS2B/M has the gearbox mid-mounted, between the rails, making it better for situations where space prohibits a side-mounted motor.

Both models are available for line widths of 160 to 1040 mm. Nominal speeds of 9, 12, 15 and 18 m/min for a number of standard voltages are available (see table 3-1 for motor and gearbox options).

The maximum total load per drive is 150 kg with a maximum conveyor length between drive and return of 50 meters. For increased capacity, Bosch also offers heavy duty drive modules (page 3-4).

The AS2B/M and AS2B/S drive modules include all hardware required to mount it to a belt conveyor section, as well as fasteners to connect drives and returns end to end

For non-standard width, speed or voltages please contact our applications engineering department.

### Outboard Mounted Motor Orientation

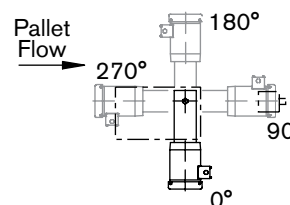

### Motor Position

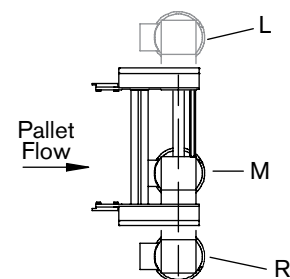

## Ordering Information for Belt Drive Unit AS2B/M, AS2B/S

AS2B/M Mid-Mounted Motor 3842 999 083		Specify center or side mounted part number, then select from the options below.	AS2B/S Outboard Mounted Motor 3842 999 190	
Your selection:	Your options are:		Your options are:	Your selection:
___ mm	160, 240, 320, 400, 480, 640, 800, 1040	Drive Unit Width*	160, 240, 320, 400, 480, 640, 800, 1040	___ mm
___ M/min	9, 12, 15 <sup>†</sup> , 18	Nominal Speed	9, 12, 15 <sup>†</sup> , 18	___ M/min
___ VAC ___ Hz	See Table 3-1	Motor Voltage/Frequency**	See Table 3-1	___ VAC ___ Hz
N/A	M	Motor Location	L, R	___
N/A	0°	Motor Orientation	0°, 90°, 180°, 270°	___

\* Drive unit width must match workpiece pallet length (L<sub>wr</sub>) or width (B<sub>wr</sub>), depending on orientation.

\*\* To omit motor, enter 0 VAC, 0 Hz.

† Only at 50 Hz; see table 3-1

Belt Drive Components

**Technical data for AS2B/M and AS2B/S drives**

Nominal conveyor speed	=	See table 3-1
Permissible loading weight	=	150 kg
Maximum conveyor unit length	=	50 m (150 ft.)
Motor RPM at 50 Hz	=	1400
Motor RPM at 60 Hz	=	1700
Motor, electrical specification	=	See table 3 - 1

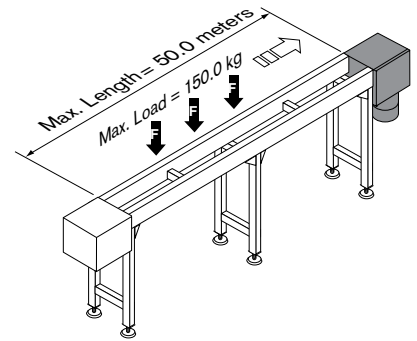

**Electrical data for AS2B/M and AS2B/S drives**

Nom. M/min	Actual Speed		HP	Full Load Amps @					
	50 Hz	60 Hz		208/60	240/60	380/50	415/50	480/60	575/60
9	8.4	10.2	0.5	1.9	1.8	0.95	0.95	0.82	0.69
12	11.0	13.4	0.5	1.9	1.8	0.95	0.95	0.82	0.69
15	15.5	N/A	0.5	N/A	N/A	0.95	0.95	N/A	N/A
18	18.2	18.9	0.5	1.9	1.8	0.95	0.95	0.82	0.69

Note: Electrical Data for reference only. Refer to motor name plate for actual amperage ratings.

Table 3-1

**Dimensional data for AS2B/M and AS2B/S drives**

